

XB2RKB2435

Beam Adjustable Linear Inground Light

1. Exterior details

1.1 Luminaire

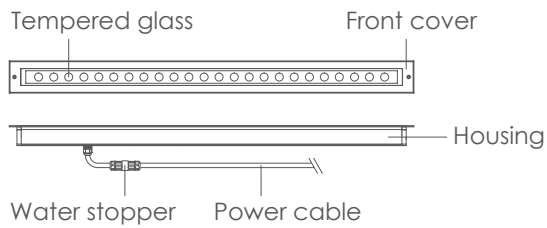

1.2 Dimension (mm)

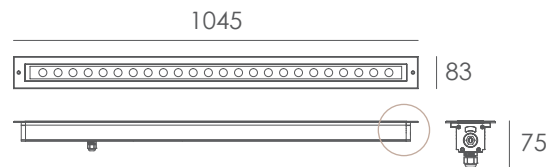

1.3 Recessed sleeve (144#)

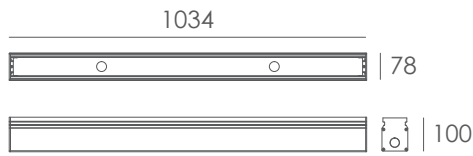

2. Datasheet

Housing:	Extruded aluminum, powder coated
Front Cover:	Hard chrome-plated stainless steel SUS 316L
Light Window:	Tempered step glass. T=6mm
Lens:	OPTICS lens. efficiency $\geq 85\%$
Cable Gland:	IP68 PG-9 PA66
Gasket:	Glass and housing are silicone sealed
Glass Pressure Capacity:	5,207kgs
Operating Temperature:	-20°C~40°C
Power Cable:	H05RN-F 2×1.0mm ² , L=0.5m
Mounting Sleeve:	Powder Coated Aluminum

Light Source:	24×1.3W
Beam Angle:	10°
Input Voltage(v):	DC 24
Operating Current(mA):	1472
Consumption(w):	35
Luminance(lm):	2977
IK:	07

3. Installation steps

Step 1

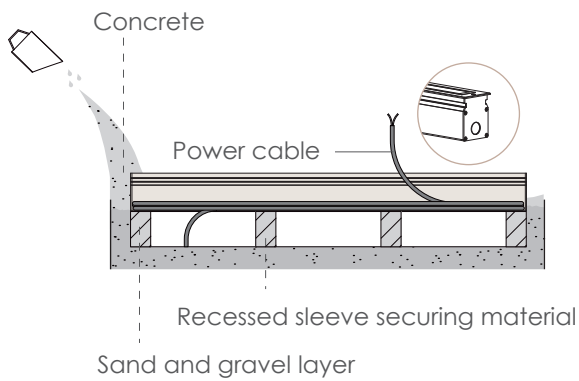

Step 2

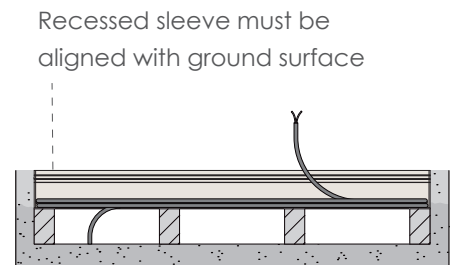

Step 3

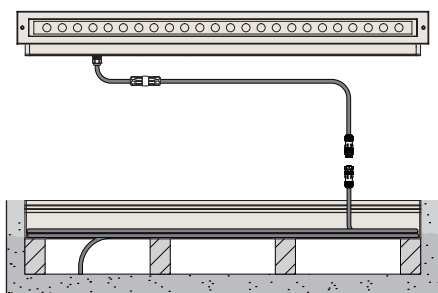

Step 4

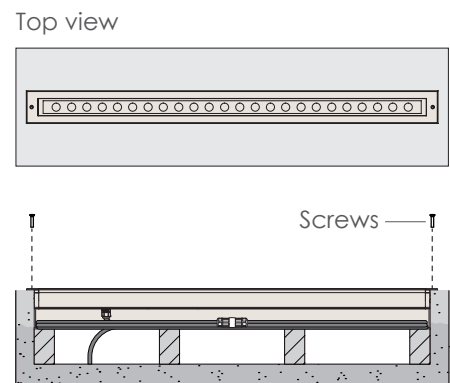

Kapego company limited

TEL:+86 076983997830
 FAX:+86 076983997833
 Email:sales@kapego.com
 Website:www.kapego.com
 East changle Road, Yuning industrial district.
 Hengli, Dongguang, guangdong, China 523478

