

1E2WP0157 PG

Soft Beam Drive-Over Capacity Inground Light

1. Exterior details

1.1 Luminaire

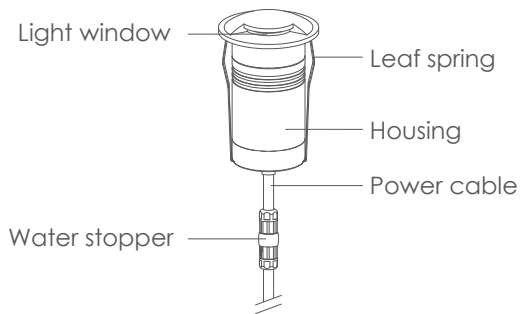

1.2 Dimension (mm)

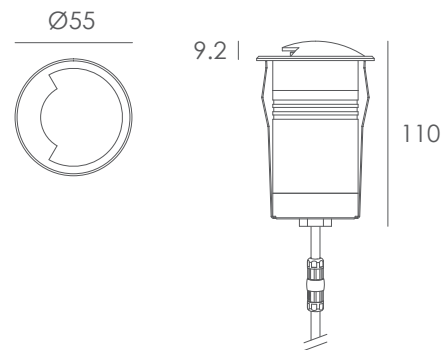

1.3 Recessed sleeve

A08

185#

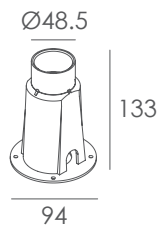
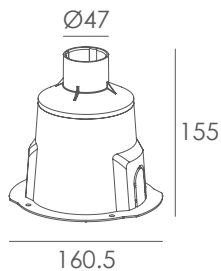

2. Datasheet

Housing:	ADC12# powder coated aluminum T=60-80 μm . Adhesion of ISO class 1/ASTM class 4B
Front Cover:	Hard chromeplated stainless steel SUS 316#
Light Window:	UVstop & Fireproof PC
Gasket:	Silicon rubber molding shaped seal
Power Cable:	H05RN-F 2 \times 1.0mm ² , L=0.5m
Recessed Sleeve Material:	PC/ABS ALLOYS
Glass Pressure Capacity:	1,820kgs
Operating Temperature:	-20°C~40°C

Light Source:	1×2W
Beam Angle:	120°
Input Voltage(v):	DC 24
Operating Current(mA):	110
Consumption(w):	2.6
Luminance(lm):	13
IK:	10

3. Installation steps

Step 1

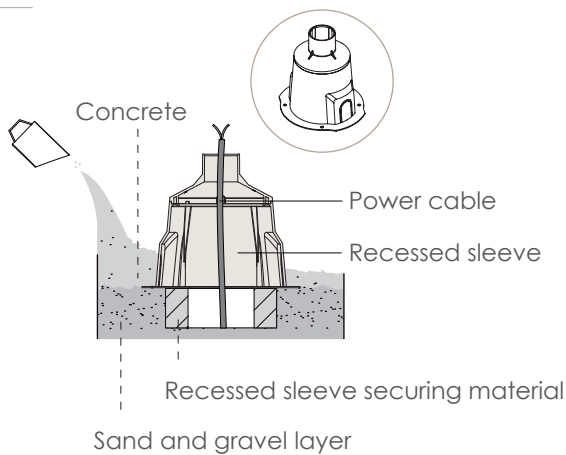

Step 2

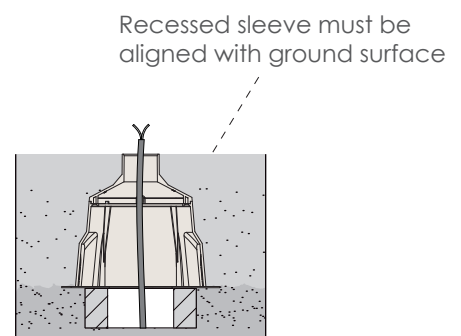

Step 3

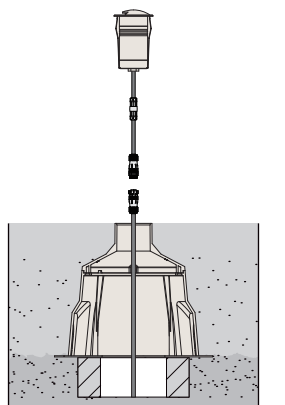

Connect the power cable

Step 4

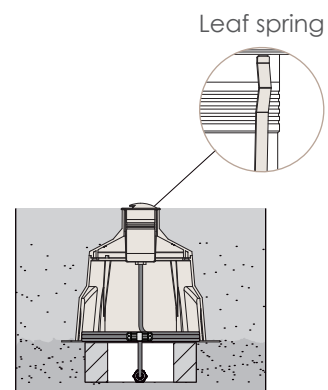

Kapego company limited

TEL:+86 076983997830
 FAX:+86 076983997833
 Email:sales@kapego.com
 Website:www.kapego.com
 East changle Road, Yuning industrial district.
 Hengli, Dongguang, guangdong, China 523478

