

# R2KFR0176

High Luminance Output Inground Flood Light

## 1. Exterior details

### 1.1 Luminaire

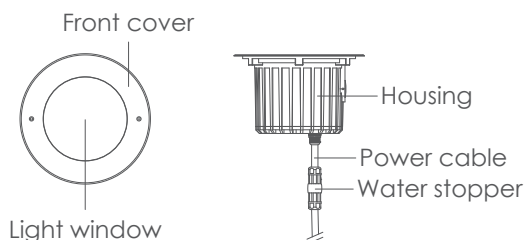

### 1.2 Dimension (mm)

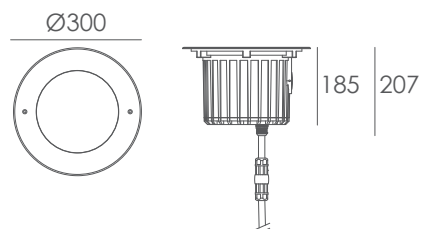

### 1.3 Recessed sleeve (106#)

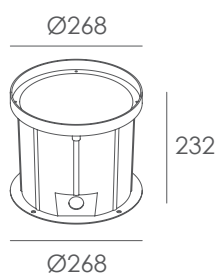

### 1.4 Honeycomb Louver

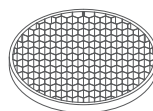

## 2. Datasheet

<b>Housing:</b>	12# Die-casting aluminum powder coated T=60-80µm Adhesion of ISO class 1/ATM class 4B
<b>Front Cover:</b>	Hard chrome-plated stainless steel SUS 316L#
<b>Light Window:</b>	Tempered step glass.T=10mm
<b>Reflector:</b>	OPTICS Reflector efficiency≥90%
<b>Glass Pressure Capacity:</b>	3,341kgs
<b>Cable Gland:</b>	IP68 PG-13.5 PA66
<b>Gasket:</b>	Silicon rubber molding shaped seal
<b>LED Driver:</b>	Constant Voltage Input,Constant Current Output
<b>Operating Temperature:</b>	-20°C~40°C
<b>Power Cable:</b>	H07RN-F 3×1.0mm <sup>2</sup> , L=0.5m
<b>Recessed Sleeve Material:</b>	PC/ABS ALLOYS

<b>Light Source:</b>	1×40W
<b>Beam Angle:</b>	24°
<b>Input Voltage(v):</b>	240
<b>Operating Current(mA):</b>	187
<b>Consumption(w):</b>	41
<b>Luminance(lm):</b>	4097
<b>IK:</b>	10

### 3. Installation steps

#### Step 1

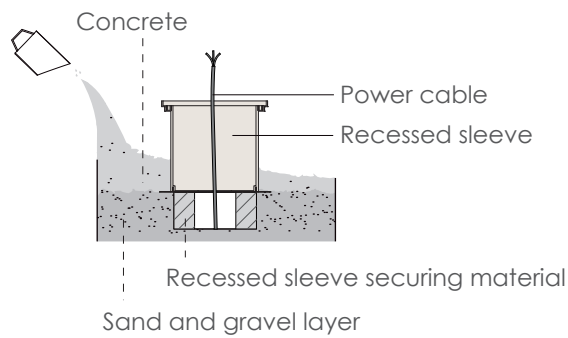

#### Step 2

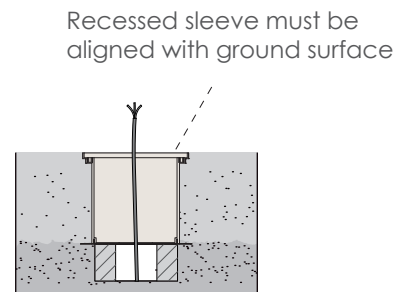

#### Step 3

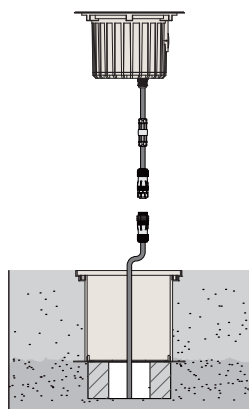

Connect the power cable

#### Step 4

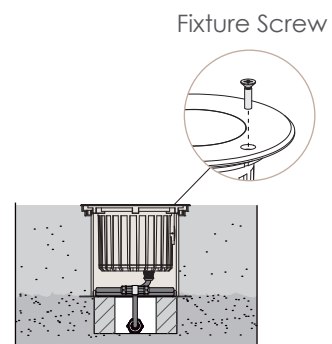

#### Kapego company limited

TEL:+86 076983997830  
 FAX:+86 076983997833  
 Email:sales@kapego.com  
 Website:www.kapego.com  
 East changle Road, Yuning industrial district.  
 Hengli, Dongguang, guangdong, China 523478

