

XB2GFR0170

Tiltable Inground Light

1. Exterior details

1.1 Luminaire

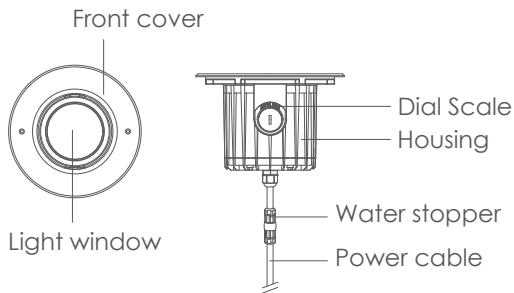

1.2 Dimension (mm)

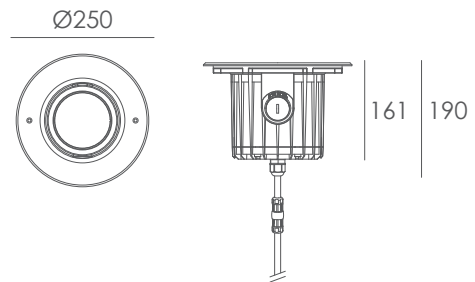

1.3 Recessed sleeve (068#)

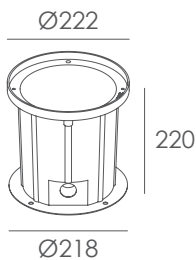

2. Datasheet

Housing:	12# Die-casting aluminum powder coated T=60-80µm Adhesion of ISO class 1/ATM class 4B
Front Cover:	Hard chrome-plated stainless steel SUS 316L#
Light Window:	Tempered step glass.T=10mm
Glass Pressure Capacity:	2,127kgs
Cable Gland:	IP68 PG-13.5 PA66
Gasket:	Silicon rubber molding shaped seal
LED Driver:	Constant Voltage Input,Constant Current Output
Operating Temperature:	-20°C~40°C
Power Cable:	H07RN-F 2×1.0mm ² , L=0.5m
Recessed Sleeve Material:	PC/ABS ALLOYS

Light Source:	1×20W
Beam Angle:	24°
Input Voltage(v):	DC 24
Operating Current(mA):	833
Consumption(w):	20
Luminance(lm):	1900
IK:	10

3. Installation steps

Step 1

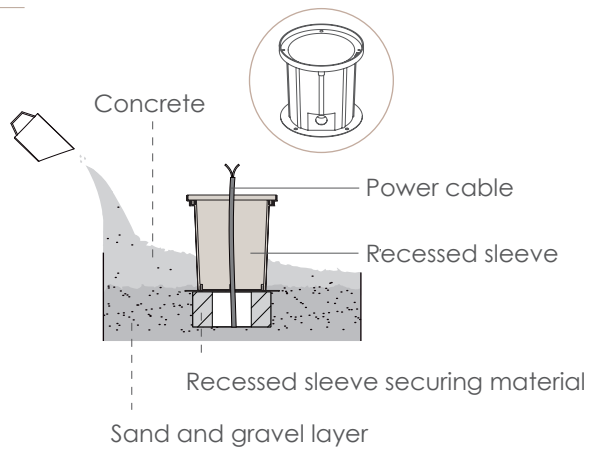

Step 2

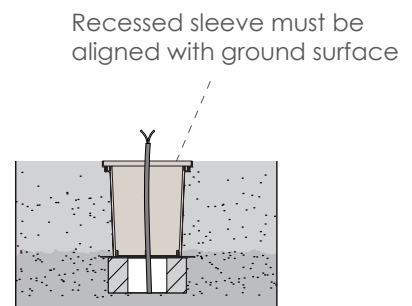

Step 3

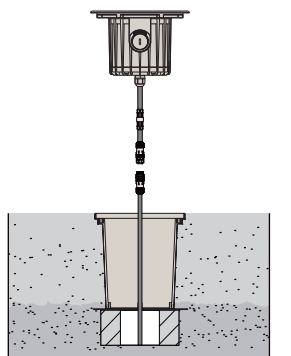

Connect the power cable

Step 4

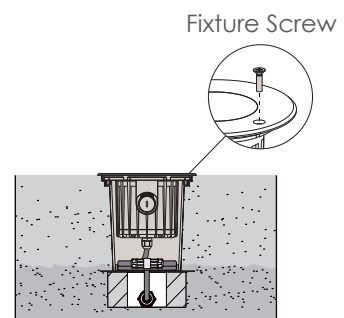

Kapego company limited

TEL:+86 076983997830
 FAX:+86 076983997833
 Email:sales@kapego.com
 Website:www.kapego.com
 East changle Road,Yuning industrial district.
 Hengli,Dongguang ,guangdong, China 523478

